

PROGEF Standard
Check valve type 562
With socket fusion spigots metric

Model:

- Material: PP-H
- For horizontal or vertical installation
- Sealing at a minimum water column of 1 m
- Spring loaded, spring made of stainless steel (1.4310)
- Spring available in other materials, see spare parts
- Designed for easy installation and removal
- Vibration free even at high flow velocity
- Flow-optimized return cone, double guided
- Compact installation length, same as ball valve type 546
- Z-length, end connectors and union nuts **not** compatible with type 360
- New DN65-DN100

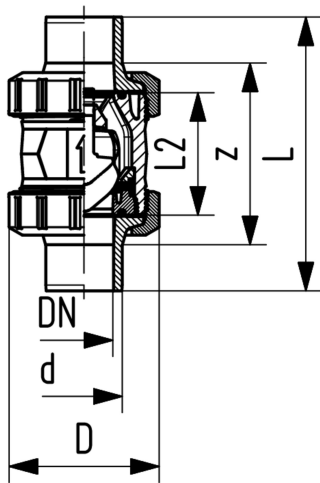

| d (mm) | DN (mm) | PN (bar) | kv-value ($\Delta p=1$ bar) (l/min) | EPDM Code | SP Weight (kg) | FKM Code | SP Weight (kg) |
|-----------|------------|-------------|--|--------------|----------------------|-------------|----------------------|
| 16 | 10 | 10 | 190 | 167 562 041 | 1 | 0.080 | 167 562 051 |
| 20 | 15 | 10 | 180 | 167 562 042 | 1 | 0.090 | 167 562 052 |
| 25 | 20 | 10 | 380 | 167 562 043 | 1 | 0.170 | 167 562 053 |
| 32 | 25 | 10 | 460 | 167 562 044 | 1 | 0.200 | 167 562 054 |
| 40 | 32 | 10 | 850 | 167 562 045 | 1 | 0.340 | 167 562 055 |
| 50 | 40 | 10 | 1080 | 167 562 046 | 1 | 0.510 | 167 562 056 |
| 63 | 50 | 10 | 1670 | 167 562 047 | 1 | 0.940 | 167 562 057 |
| 75 | 65 | 10 | 2950 | 167 562 048 | 1 | 2.360 | 167 562 058 |
| 90 | 80 | 10 | 3600 | 167 562 049 | 1 | 3.730 | 167 562 059 |
| 110 | 100 | 10 | 4150 | 167 562 050 | 1 | 5.960 | 167 562 060 |

| d (mm) | D (mm) | L (mm) | L2 (mm) | closest inch (inch) |
|-----------|-----------|-----------|------------|---------------------------|
| 16 | 50 | 110 | 56 | 3/8 |
| 20 | 50 | 120 | 56 | 1/2 |
| 25 | 58 | 139 | 65 | 3/4 |
| 32 | 68 | 150 | 71 | 1 |
| 40 | 84 | 170 | 85 | 1 1/4 |
| 50 | 97 | 190 | 89 | 1 1/2 |
| 63 | 124 | 220 | 101 | 2 |
| 75 | 166 | 280 | 136 | 2 1/2 |
| 90 | 200 | 296 | 141 | 3 |
| 110 | 238 | 336 | 164 | 4 |

The technical data are not binding. They neither constitute expressly warranted characteristics nor guaranteed properties nor a guaranteed durability. They are subject to modification. Our General Terms of Sale apply.

Georg Fischer Piping Systems Ltd, Postfach, CH-8201 Schaffhausen/Switzerland

Phone +41 -(0)52-631 1111

e-mail: info.ps@georgfischer.com

Internet: <http://www.gfps.com>