

ARTICULO: 2461

Filtro " Y " extremos bridados

Flanged ends " Y " Strainer

Características
1. Filtro "Y".
2. Extremos bridados según EN 1092 PN16.
3. Longitud entre caras según EN 558 serie 1 (DIN 3202 F1).
4. Construcción en acero inoxidable 1.4408 (CF8M).
5. Tapón de purga G1/2" a partir de la medida 1 1/4".
6. Presión de trabajo máxima 16 bar.
7. Temperatura de trabajo -30 °C + 240 °C.

Features
1. " Y "Strainer.
2. Flanged ends according to EN 1092 PN16.
3. Face to Face according to EN 558 series 1 (DIN 3202 F1).
4. Made of Stainless Steel 1.4408 (CF8M).
5. Drain plug G1/2" from size 1 1/4".
6. Max. Working pressure 16 bar.
7. Working temperature -30 °C + 240 °C.

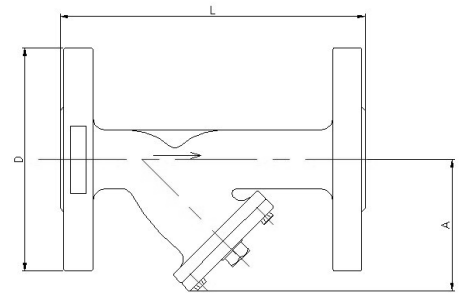
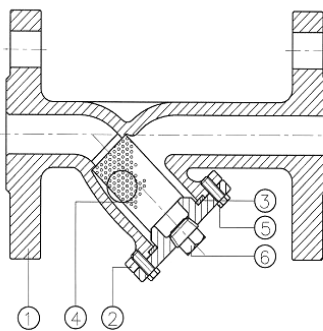

Nº	Denominación / Name	Material	Acabado Superficial / Surface Treatment	Cód. Recambio Spare Part Code
1	Cuerpo / Body	Acero Inox. / Stainless Steel 1.4408	Granallado / Shot blasting	-----
2	Tapa / Cover	Acero Inox. / Stainless Steel 1.4408	Granallado / Shot blasting	-----
3*	Junta / Gasket	PTFE	-----	J2461
4*	Tamiz / Mesh	Acero Inox. / Stainless Steel AISI 316	-----	2861
5	Tornillo / Bolt	Acero Inox. / Stainless Steel AISI 304	-----	-----
6	Tapón / Plug	Acero Inox. / Stainless Steel AISI 316	A partir de 1 1/4" / From size 1 1/4"	-----

* Piezas de recambio disponibles / Available spare parts

Detalle de la Malla / Mesh detail:

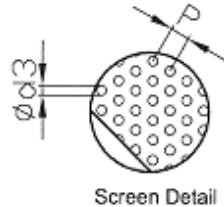

Screen Detail

DIMENSIONES GENERALES / GENERAL DIMENSIONS

Ref	Medida / Size	PN	Dimensiones / Dimensions (mm)					Peso / Weight (Kg)
			A	D	L	P	d 3	
2461 04	1/2"	16	75	95	130	2	1	1.95
2461 05	3/4"	16	90	105	150	2	1	2.75
2461 06	1"	16	100	115	160	2	1	3.70
2461 07	1 1/4"	16	115	140	180	2	1	5.90
2461 08	1 1/2"	16	130	150	200	2	1	6.40
2461 09	2"	16	150	165	230	2	1	8.90
2461 10	2 1/2"	16	190	185	290	3.5	2	12.95
2461 11	3"	16	200	200	310	3.5	2	18.15
2461 12	4"	16	230	220	350	3.5	2	24.30
2461 13	5"	16	280	250	400	3.5	2	30.00
2461 14	6"	16	300	285	480	3.5	2	42.00
2461 16	8"	16	400	340	605	3.5	2	75.00

VALORES DE Kv / Kv VALUES

Kv = Es la cantidad de metros cúbicos por hora (m³/h) que pasará a través de la válvula generando una pérdida de carga de 1 bar.

Kv = Flow rate of water in cubic meter per hour (m³/h) that will generate a pressure drop of 1 bar across the valve.

D	Inch	1/2"	3/4"	1"	1 1/4"	1 1/2"	2"	2 1/2"	3"	4"	5"	6"	8"
Kv	m ³ /h	3,30	6,60	9,70	14,90	26,60	35,40	67,20	96,10	149,00	198,50	294,60	462,50

DIAGRAMA DE PÉRDIDAS DE CARGA / HEAD LOSS CHART

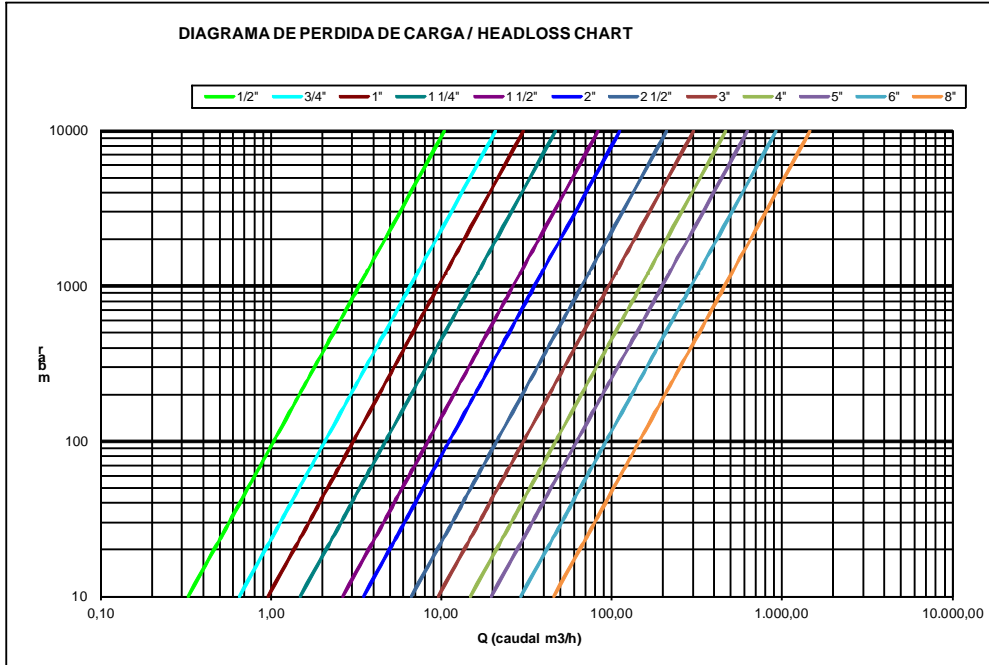

CURVA PRESION TEMPERATURA / PRESSURE TEMPERATURE RATING

