

# IN-LINE FLOW REGULATOR SERIES RFLX

The in-line flow regulator regulates the speed of the piston rod in the pneumatic cylinders.

Two versions are available:

- type U (unidirectional) regulates the flow only in one of the two directions of air flow.
- type B (bidirectional) regulates the flow in both directions of air flow.

Regulation: manual or with box wrench.

AISI 316L (EN 1.4404) stainless steel body

The gasket are in FKM/FPM.

## CERTIFIED

- NSF/ANSI 169 standard: products in contact with food.



COMPONENT

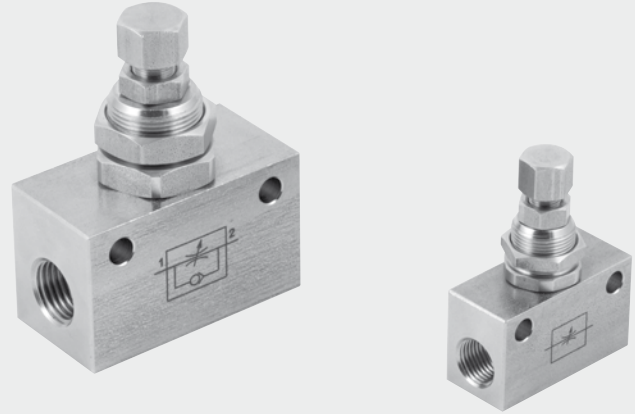

## TECHNICAL DATA

		1/8"	1/4"
Max input pressure	MPa	1	
	bar	10	
	psi	145	
Temperature range	°C	0 to 150	
	°F	32 to 302	
Max flow rate on regulation at 6.3 bar	Nl/min	110	650
Max flow rate on exhaust at 6.3 bar with closed needle	Nl/min	130	500
Max flow rate on exhaust at 6.3 bar with open needle	Nl/min	140	670
Regulation		Box wrench	
Internal system		Tapered needle	
Fluid		Filtered, lubricated or unlubricated compressed air	

## COMPONENTS

- ① BLOCK: AISI 316L stainless steel
- ② REGULATION NEEDLE: AISI 316L stainless steel
- ③ WALL LOCKING RING NUT: AISI 316L stainless steel
- ④ GASKET: FKM/FPM
- ⑤ NIPPLE: AISI 316L stainless steel

